

BELLAGIO  
VILLA



PAOLO CASTELLI



**BELLAGIO VILLA**

ENTRANCE  
MASTER DINING  
MASTER LIVING  
FAMILY DINING  
FAMILY LIVING  
GREENKISS BEDROOM  
INSPIRATION BEDROOM  
OUTDOOR

---

TECHNICAL DRAWINGS



# BELLAGIO VILLA

Before being a company, **Paolo Castelli** is the story of a family from Bologna that has been active in the furniture industry since 1887: from the Castelli cabinet-maker's shop to the business as it is today, in which artistic know-how has been the internal driving force behind development for over a century.

**Paolo Castelli** has three design collections:

**Inspiration:** furniture and lighting, a complete catalogue to unleash the perspectives of silently elegant furnishing.

**Greenkiss:** the world's first collection of furnishings with a green touch: born from a collaboration with French designers Hubert De Malherbe and Thierry Lemaire, a subtle alchemy between design and the rigorous choice of raw materials. A global approach to sustainable development that steers the collection towards a lower environmental impact. In 2022, the company presented the GreenKiss Outdoor collection

**Morandi:** a collection inspired by Giorgio Morandi, the great painter from Bologna. It proposes designer objects and furnishing accessories with a strong identity, dressed in art, colours and creativity.

The Paolo Castelli Salone booth at **Salone del Mobile 2022** is a museum room that, in a very refined way, not only conveys the company's philosophy, but the research for sustainable materials and the contemporary style attitude as well, as the result of the best craftsmanship made in Italy.

Here following our ideal house "**Bellagio Villa**".

**Paolo Castelli**, prima che un'azienda, è la storia di una famiglia bolognese che dal 1887 opera nell'arredo: dall'ebanisteria Castelli sino all'attuale realtà imprenditoriale, dove l'arte del "saper fare", è il motore interno dello sviluppo, da più di un secolo.

**Paolo Castelli** presenta tre collezioni:

**Inspiration:** arredi e illuminazione, catalogo completo che permette di liberare le prospettive di un arredo dall'eleganza silenziosa.

**Greenkiss:** prima collezione al mondo di arredi dal green touch: nasce dalla collaborazione con i designers francesi Hubert De Malherbe e Thierry Lemaire, una sottile alchimia tra il progetto e la scelta rigorosa delle materie prime. Un approccio globale allo sviluppo sostenibile che orienta la collezione, verso un minor impatto ambientale.

Nel 2022 la collezione si arricchisce degli arredi outdoor.

**Morandi:** collezione ispirata al grande pittore bolognese Giorgio Morandi. Propone oggetti d'autore e complementi d'arredo con un forte valore identitario, che si vestono d'arte, di colore e di creatività

Lo spazio allestito al **Salone del Mobile 2022** è uno spazio museale che racconta in modo raffinato la filosofia dell'azienda, la ricerca di materiali sostenibili e l'attitudine a uno stile contemporaneo frutto del miglior savoir faire artigianale made in Italy.

Di seguito gli ambienti della nostra casa ideale "**Bellagio Villa**".





Golden disc suspension lamp  
Uffizio bookcase  
Dione dining table





ENTRANCE



Stellantis suspension lamp  
Soreluna floor lamp  
Ipanema sofa



Manta suspension lamp  
Ellipse dining table rectangular  
U chair  
Anodine table lamp  
Soft ratio low cabinet  
Parabolica armchair  
Parabolica ottoman  
Ellipse Coffee Table 40







Manta suspension lamp  
Ellipse dining rectangular table  
U chair







- Golden cloud round chandelier
- Golden cloud wall lamp
- Colette table lamp
- Anodine wall lamp
- Soft ratio composition sofa
- Soft ratio coffee table
- Ottoman stool
- Venice swing armchair
- Dione coffee tables
- For living cocktail cabinet
- Petra bookshelves



Ottoman stool  
Petra bookshelves





Labilis 10 rings chandelier  
Joy 3 rings suspension lamp  
Alba dining table rectangular  
Echo chair  
For living high cabinet



Fair light wall lamp  
For living showcase cabinet  
Joy 3 rings suspension lamp  
Alba dining table rectangular  
Echo chair







My lamp ceiling 140  
Kaala table lamp  
Icône lumineuse floor lamp  
Vao sofa 380  
Vao sofa 250  
Vao armchair  
Vao pouf  
Selima tv cabinet  
Arche coffee tables



Vao armchair  
Luna armchair  
Nettuno table lamp  
Hyperbole coffee table



LIVE

INTO YOUR DREAMS







Vao bed  
Hyperbole coffee table  
Icône lumineuse table lamp  
Vao pouf





Allure round chandelier  
Circle wall lamp  
Comet floor lamp  
Ama sofa composition  
Ama sofa  
Ama armchair  
Claude coffee tables





Ama sofa  
Circle wall lamp  
Claude coffee table

Ama armchair

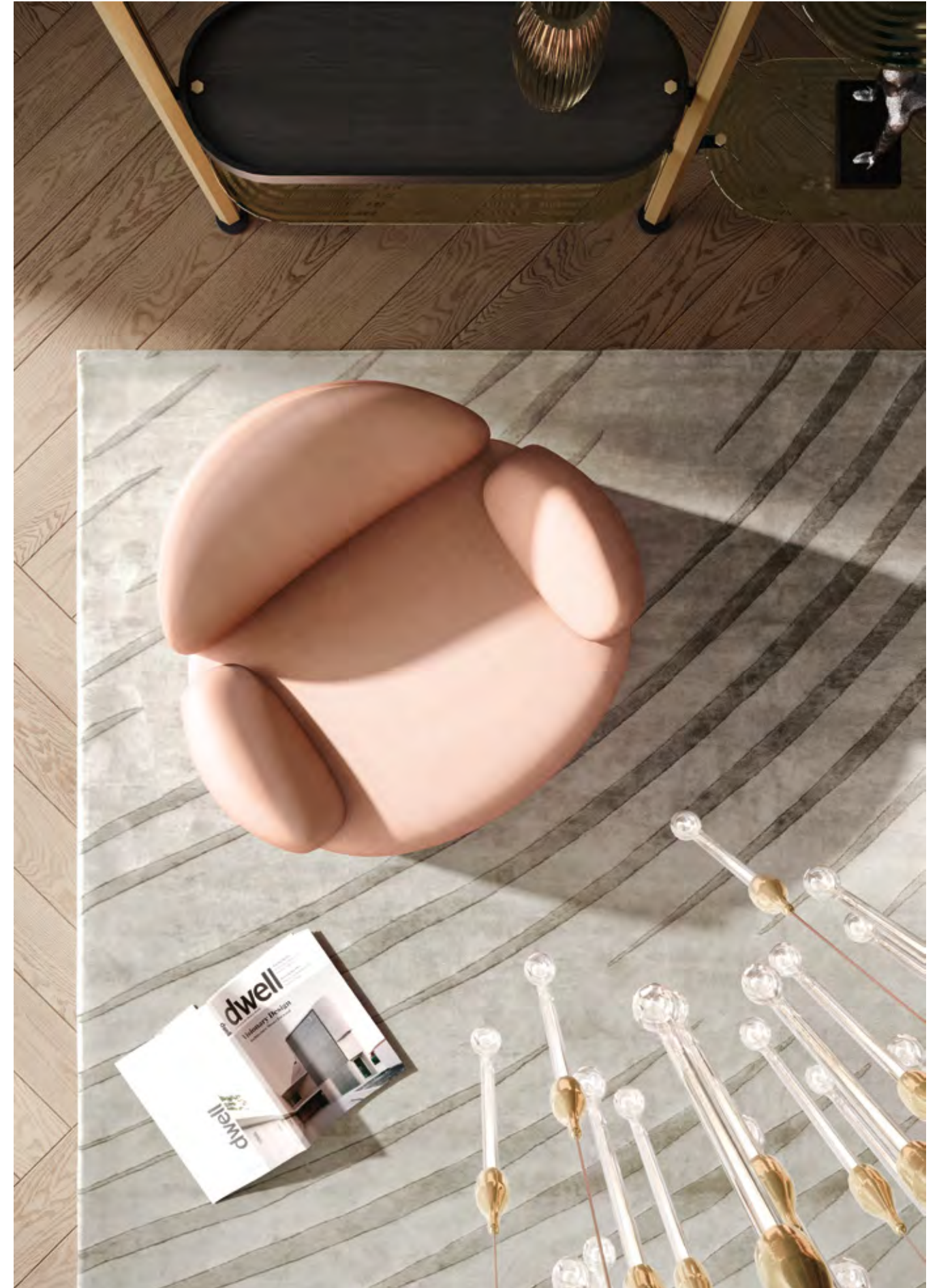



BREATHE YOUR LIVING





Imane sofa outdoor collection  
Terminal outdoor lighting collection

AMA\_design Paolo Castelli

**AMA is a collection of sofas and armchairs with a slightly decò image.** The shape and proportion of the different compositional elements - the high seat, the rounded backrest, the particular shape of the armrests - make the whole elegant and scenographic. The refined and expressive armchair is characterized by a round padded seat, raised thanks to the backrest and armrests that extend to the ground. Sofas and armchair have a solid wood and plywood frame, and a full-bodied polyurethane padding with polyester fiber covering and cotton lining. The slightly visible feet are available in wood with a dark stained Ash finish.

**AMA è una collezione di divani e poltrona dall'immagine delicatamente decò.** La forma e proporzione dei diversi elementi compositivi - la seduta alta, lo schienale arrotondato, la forma particolare dei braccioli - rende l'insieme elegante e scenografico. La poltrona, raffinata ed espressiva, è caratterizzata da una seduta imbottita rotonda, sollevata grazie allo schienale e ai braccioli che si prolungano a terra. Divani e poltrona hanno una struttura in legno massello e multistrato, e una imbottitura corposa in poliuretano con rivestimento in fibra di poliestere e fodera in cotone. I piedini leggermente a vista sono proposti in legno con finitura Frassino tinto scuro.



AMA COMPOSITION LEFT

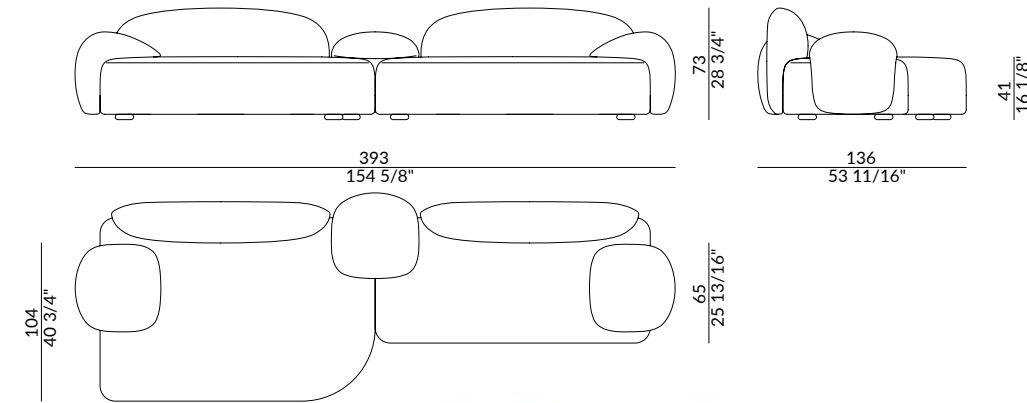

AMA ARMCHAIR

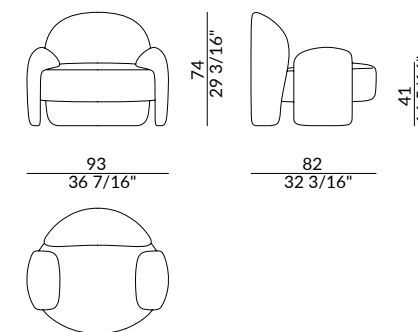

AMA SOFA

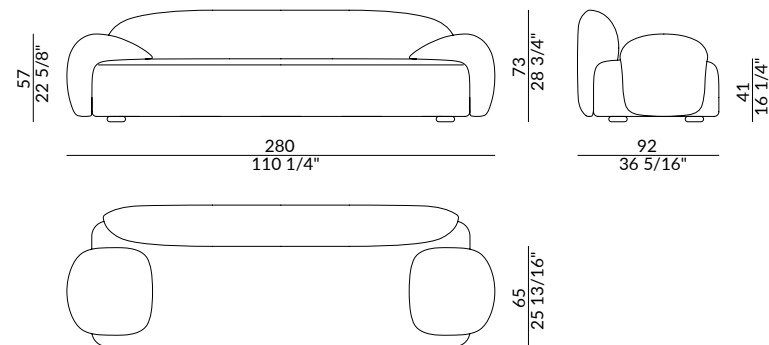

IPANEMA\_design Thierry Lemaire

**IPANEMA, the new living collection consisting of sofa, armchair and coffee table, is a free tribute to the sophisticated and timeless expressiveness of French furnishings.**

**The three-seater sofa and the IPANEMA armchair** interpret, through rigorous, but delicate and never rigid lines, the comfort at the maximum extent. The structure – made of a metal frame with matt black satin nickel finish and matt gold for the feet – contains full-bodied cushions and soft seats made of polyester fiber with an insert in non-deformable material of different densities. The back cushions and the armrests are made of polyurethane with polyester fiber covering to ensure optimal support and be equally soft and welcoming. For extra comfort, the cushions also have additional sterilized goose down filling. All cushions and backrests are removable.

**IPANEMA, la nuova collezione living composta da sofà, la poltrona e il coffee table, è un libero tributo alla espressività sofisticata e senza tempo degli arredi francesi.**

**Il sofà a tre posti e la poltrona IPANEMA** interpretano il massimo comfort attraverso linee rigorose ma delicate, mai rigide. La struttura - rappresentata da un frame in metallo con finitura nichel nero opaco satinato e oro opaco per i piedi - accoglie cuscini seduta corposi e soffici realizzati in fibra di poliestere con inserto in materiale indeformabile a densità differenziata. I cuscini schienale e i braccioli sono realizzati in poliuretano con rivestimento in fibra di poliestere per garantire un sostegno ottimale per essere in egual modo morbidi e accoglienti. Per un extra comfort, i cuscini schienale hanno anche un'imbottitura aggiuntiva in piuma d'oca sterilizzata. Tutti i cuscini seduta e schienale sono sfoderabili.



IPANEMA SOFA 2 SEATS

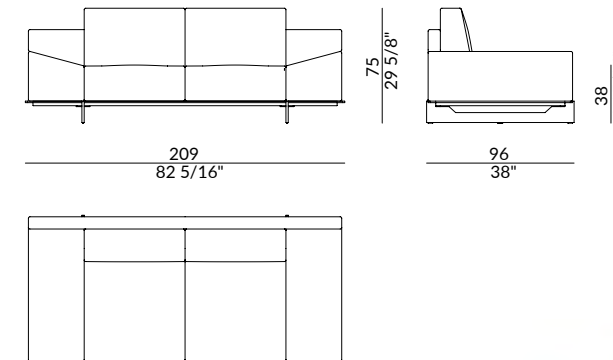

IPANEMA ARMCHAIR

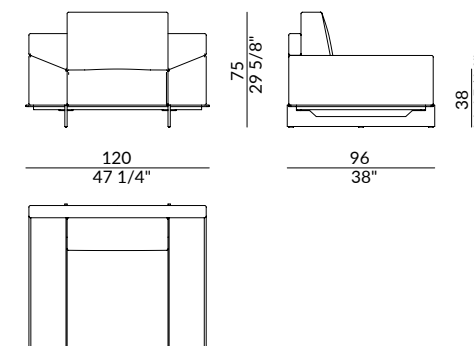

IPANEMA SOFA 3 SEATS

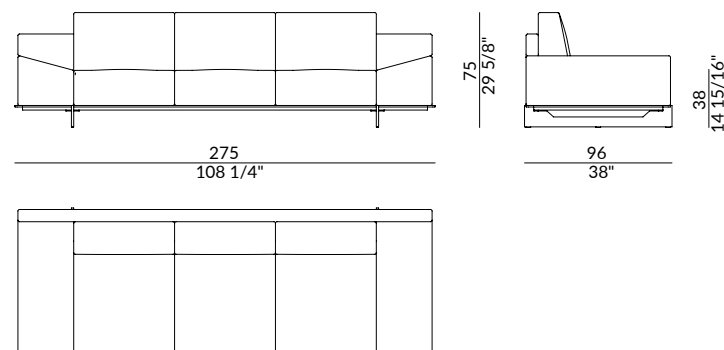

ELLIPSE\_design Paolo Castelli

**ELLIPSE is a refined collection of tables and coffee tables with a sculptural image, defined by curved lines and rounded surfaces. The tables**, offered in round and oval versions, are characterized by the refined combination of two materials: Nero Marquina marble and metal. The black marble top - in a single slab turned from a block - is made even more precious by the glossy finish and the rounded edge. The base is composed of two distinct elements: a marble cylinder and a curved calendered metal sail with an internal matt black finish and an external matt brass bronze finish. In the round version they intersect, composing a central base, while in the oval version they are two distinct elements which give a special scenographic allure to a table. **The coffee tables**, imagined in two sizes and two heights, are made of metal. The round top is a metal plate with a matt brass bronze, circular satin finish; the base is a curved sail in calendered metal with an internal matt black finish and an external matt brass bronze finish. Perfect as they are, either individually or in pairs, they give an expressive and sculptural touch to every space, despite their refined essentiality.

**ELLIPSE è una raffinata collezione di tavoli e coffee table dall'immagine scultorea, definita da linee curve e superfici arrotondate. I tavoli**, proposti in versione rotonda e ovale, sono caratterizzati dal raffinato abbinamento di due materiali: marmo Nero Marquina e metallo. Il piano in marmo nero - in lastra unica tornita da blocco - è reso ancora più prezioso dalla finitura lucida e dal bordo arrotondato. La base è composta da due elementi distinti: un cilindro in marmo e una vela curva in metallo calandrato con finitura interna nero opaco e finitura esterna bronzo ottone opaco. Nella versione rotonda si intersecano componendo una base centrale, nella versione ovale sono due elementi distinti e danno al tavolo una speciale allure scenografica. **I coffee table**, immaginati in due misure e due altezze, sono realizzati in metallo. Il piano rotondo è una lastra metallica con finitura bronzo ottone opaco con satinatura circolare; la base è una vela curva in metallo calandrato con finitura interna nero opaco e finitura esterna bronzo ottone opaco. Perfetti anche singolarmente, in coppia regalano un tocco espressivo e scultoreo, pur nella loro raffinata essenzialità.



ELLIPSE ROUND

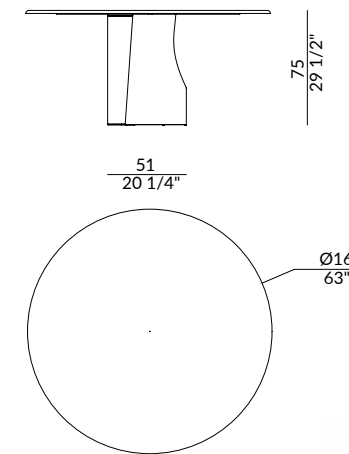

ELLIPSE RECTANGULAR

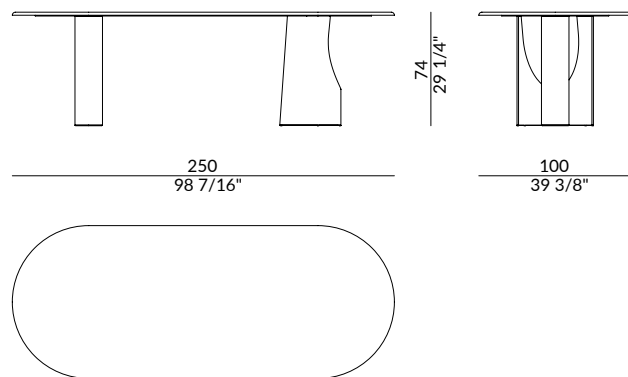

ELLIPSE COFFEE TABLE  
40

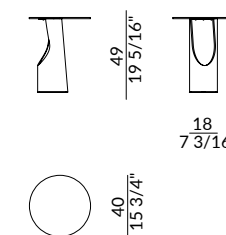

ELLIPSE COFFEE TABLE  
60

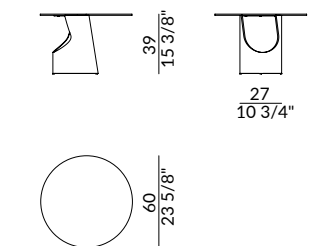

**IPANEMA COFFEE TABLE**\_design Thierry Lemaire

The two IPANEMA coffee tables, with their essential presence, complete the timeless elegance of the chairs. Like the whole IPANEMA collection, they are available with a metal structure with a matt black nickel finish that supports and "holds" the precious 10 cm thick rectangular marble top on one side. The coffee tables are available in three types of marble: Grand noir Antique, Calacatta, Sahara Noir and polished Frakè wood.

I due coffee table IPANEMA completano l'eleganza senza tempo delle sedute con la loro presenza essenziale. Come tutta la collezione IPANEMA, sono caratterizzati da una struttura in metallo con finitura nichel nero opaco che sostiene e "ferma" da un lato il prezioso piano in marmo rettangolare dello spessore di 10 cm. I coffee table proposti in tre qualità pregiate di marmo: Grand noir Antique, Calacatta, Sahara Noir e in legno Frakè lucido 100 gloss.

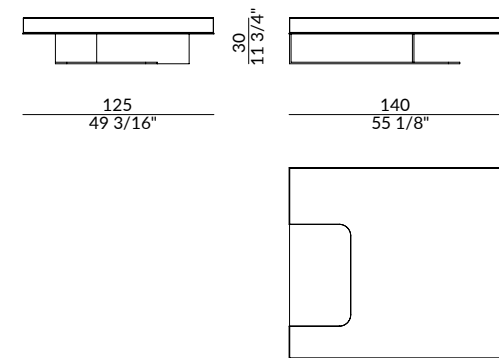

MOD 140

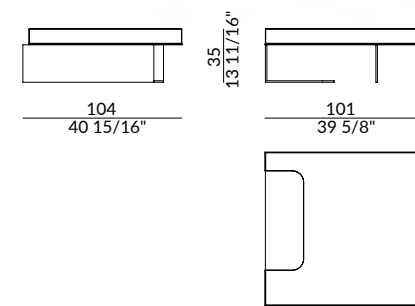
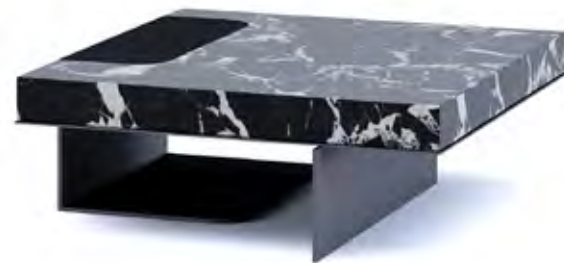

MOD 101

**BAR TABLE**\_design Paolo Castelli

BAR TABLE is a refined table that recalls the atmosphere of the Parisian bistros. With an iconic, simple and elegant image, the BAR TABLE has a round top in back-lacquered glass, a metal leg with a matt black finish and a circular base in satin brass. Perfect for the elegant interior of bars and bistros furnishings, it is also suitable for making terraces and dehors welcoming and elegant.

BAR TABLE è un raffinato tavolino da bar che ricorda l'atmosfera dei bistrot parigini. Dall'immagine iconica, semplice ed elegante con un piano rotondo proposto in vetro retrolaccato, gamba in metallo con finitura nero opaco e base circolare in ottone satinato. Perfetto per arredare con eleganza l'interno di bar e bistrot, è adatto anche per rendere accogliente ed elegante terrazze e dehors.



BAR TABLE

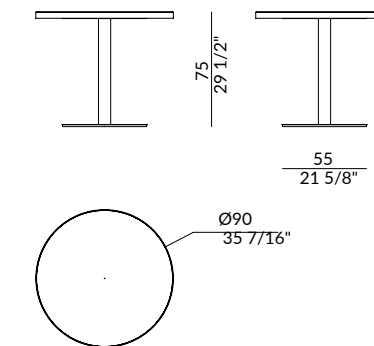



**MANTA**\_design Vittorio Paradiso

**MANTA is a scenographic suspension lamp whose ethereal lightness recalls the iconic furniture by Alexander Calder.** The circular ceiling support is made of satin brass. The lighting bodies with LED sources are amber-colored glass leaves, hand-forged by the master glassmakers of Murano. They have a delicate and sinuous shape and seem to fly in the air, hanging from very thin electrified suspension cables.

**MANTA è una scenografica lampada a sospensione che per la sua eterea leggerezza ricorda gli iconici mobili di Alexander Calder.** Il supporto circolare a soffitto è realizzato in ottone satinato. I corpi illuminanti con sorgente a LED sono foglie in vetro color ambra, forgiate a mano dai maestri vetrai di Murano. Hanno una forma delicata e sinuosa e sembrano volare nell'aria, appese a sottilissimi cavi di sospensione elettrificata.

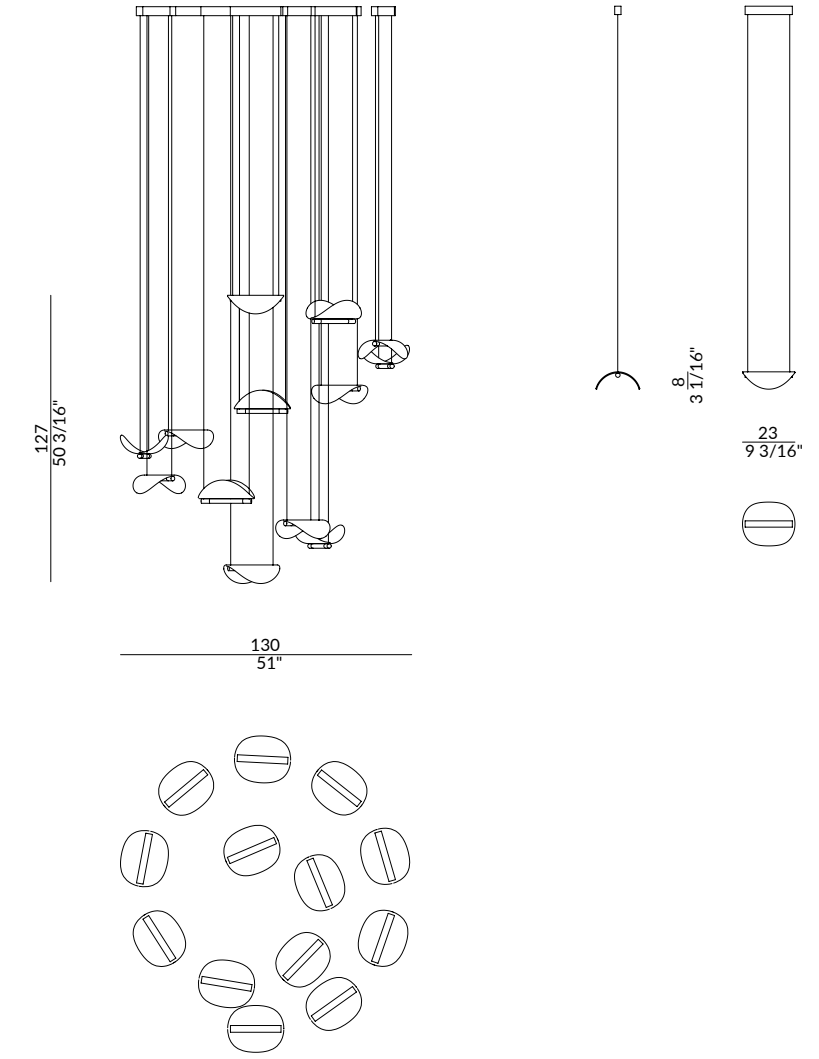

STELLANTIS\_design Paolo Castelli

**STELLANTIS is a suspended light sculpture, designed to become the focal point of the environment.** Suggestive and poetic, it is a composition of six glass cones with a metallic bronze shade - Handmade in Murano glass masters - fixed on a vertical brass rod. Illuminated by a LED source, the glass elements diffuse iridescent reflections into the environment with an expressive and scenographic effect. Also dimmable.

**STELLANTIS è una scultura luminosa sospesa, immaginata per diventare il centro focale dell'ambiente.** Suggestiva e poetica, è composta da sei coni in vetro con sfumatura metallizzata bronzo - realizzati a mano dai maestri vetrai di Murano - fissati su un'asta verticale in ottone. Illuminati da sorgente a LED, gli elementi in vetro diffondono nell'ambiente riflessi cangianti con un effetto espressivo e scenografico. Anche dimmerabile.

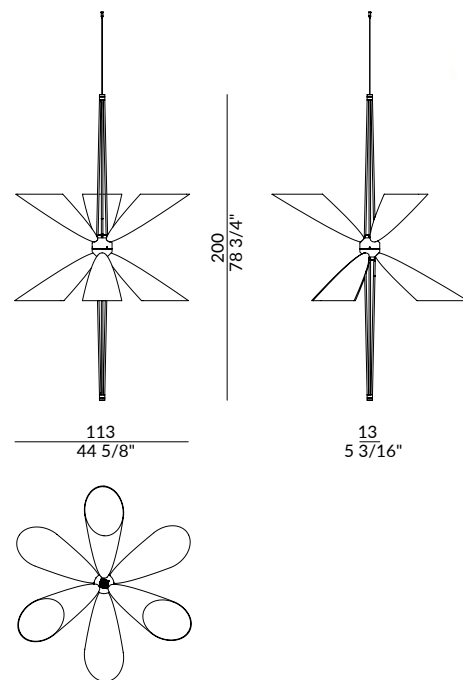

ICONE LUMINOSE LAMPADA DA TAVOLO\_design Paolo Castelli

**The series of lamps of the Castelli Art line, Morandi collection is enriched with a new table version lamp.** The body is composed of a blown Murano glass vase in the shapes and colors already available in the collection, which offer a sophisticated touch to any type of setting. The lampshade is in natural canvas handcrafted.

**La serie di lampade della linea Castelli Art, collezione Morandi si arricchisce di una nuova lampada versione da tavolo.** Il corpo è composto da un vaso in vetro soffiato di Murano nelle forme e colori già disponibili a collezione, che offrono un tocco sofisticato a qualsiasi tipo di ambientazione. Il paralume è in tela naturale realizzato artigianalmente.



01



02

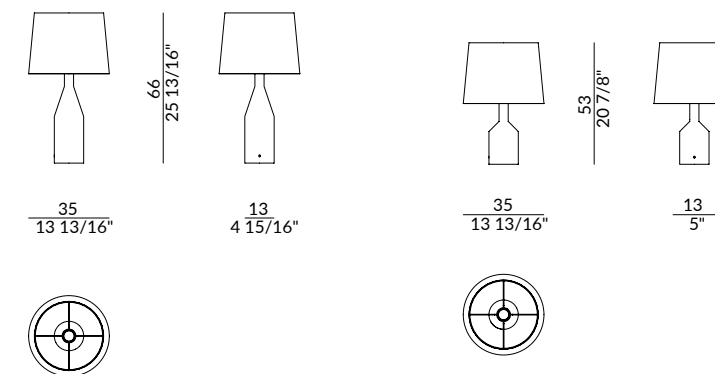

PETRA\_design Vittorio Paradiso

**PETRA was born from the idea of designing an elegant and light free-standing day system, perfect also for ideally separating the spaces of the house.** Arranged around vertical aluminum mounting brackets with a matt gold finish, the system leaves great compositional freedom thanks to the possibility of alternating shelves in sandblasted bronze tempered glass and shelves / tray in multilayer and solid wood with dark stained ash finish. Both types are characterized by a refined hexagonal shape that softens the depth of the system and makes the whole even more elegant and light. Feet and shelf support pins are made of brass.

**PETRA nasce dall'idea di progettare un sistema giorno free-standing elegante e leggero, perfetto anche per separare idealmente gli spazi della casa.** Organizzato intorno a montanti verticali in alluminio con finitura oro opaco, il sistema lascia grande libertà compositiva grazie alla possibilità di alternare ripiani in vetro temperato bronzo sabbato e ripiani/vassoio in multistrato e massello con finitura Frassino tinto scuro. Entrambe le tipologie sono caratterizzate da una raffinata forma esagonale che addolcisce la profondità del sistema e rende l'insieme ancora più elegante e leggero. Piedini e perni reggimensola sono realizzati in ottone.



**NOTES**

- The mounting bracket, H max 3450mm, can be made to measure, at no extra cost
- The height at which the shelves are positioned is at the client's discretion
- The system involves anchoring the mounting brackets at the floor and ceiling/wall
- Glass shelf capacity W 530mm Kg.15 / W 830mm Kg.23
- Wooden shelf capacity W 530mm Kg.9 / W 830mm Kg.15

**Wall fixing**

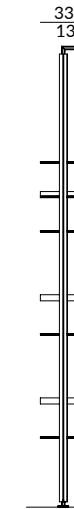

**Compositional ceiling fixing diagram**

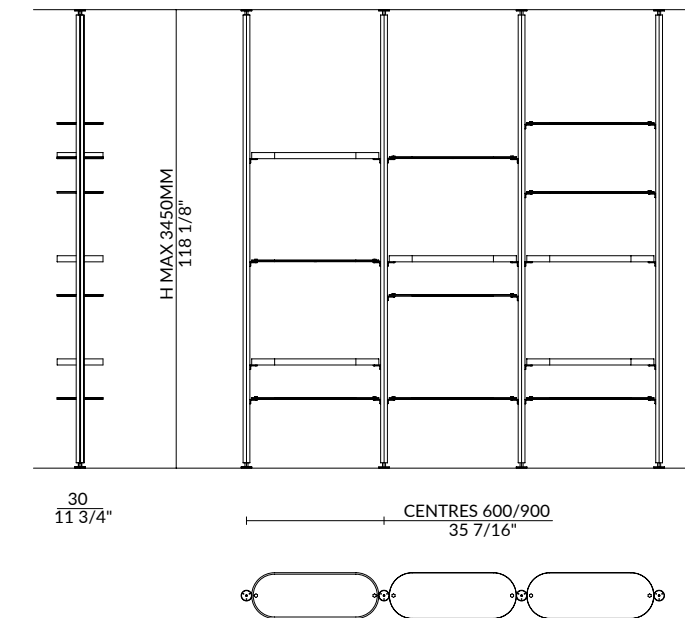

**Mounting brackets**

Ceiling Wall

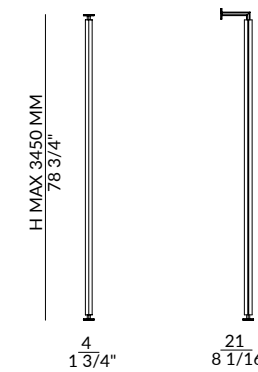

**Shelves**

Glass 830 Glass 530

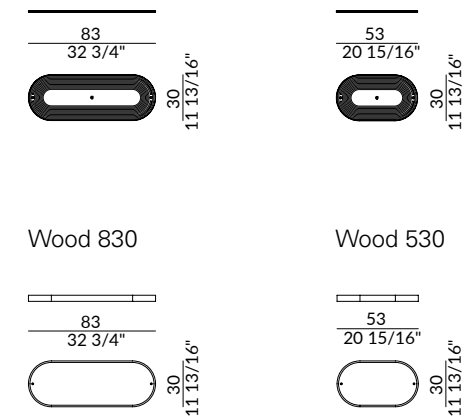

**OTTOMAN\_** design Paolo Castelli

**OTTOMAN is a seat without backrest, with an iconic, light and informal image.** Its apparent simplicity highlights the grace of the design and the refinement of the details. Made of EPS (Expanded Sintered Polystyrene) resin with a metallic acid-etched zinc finish, it is light, resistant and waterproof. Perfect in any environment, even individually, it can have many lives and many different uses.

**OTTOMAN è una seduta senza schienale dall'immagine iconica, leggera e informale.** La sua apparente semplicità lascia in evidenza la grazia del disegno e la raffinatezza dei dettagli. Realizzata in EPS (Polistirene Espanso Sinterizzato) resinato con finitura metallizzata zinco acidato, è leggera, resistente e impermeabile. Perfetta in ogni ambiente, anche singolarmente, può avere tante vite e tanti usi diversi.

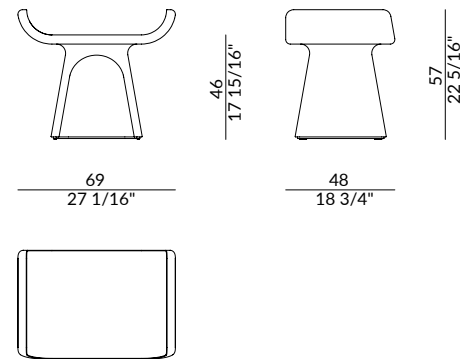

**VAO BED\_**T. Lemaire, H. De Malherbe, P. Castelli

**To the VAO sofa and armchair collection – part of the GREENKISS line dedicated to projects with a green soul – the new upholstered bed has been added,** with sinuous shapes and generous dimensions and in harmony with the mood of the collection. The bed has structure and legs in eco-sustainable solid ash while the upholstered headboard and bed frame are made with organic rubber and natural wadding. Even the bouclé wool upholstery has a natural and ecological soul. VAO also exists in a more enveloping version equipped with two movable lateral “wings” that embrace the bedside tables.

**Alla collezione divani e poltrone VAO – parte della linea Greenkiss dedicata a progetti dall'anima green – oggi si aggiunge un nuovo letto imbottito,** caratterizzato da forme sinuose e da dimensioni generose, in armonia con il mood della collezione. Il letto ha struttura e gambe in massello di frassino ecosostenibile. Testata e giroletto imbottiti sono realizzati con gomme biologiche e ovatta naturale. Anche il rivestimento in lana bouclé ha un'anima naturale ed ecologica. VAO esiste anche in una versione più avvolgente dotata di due “ali” laterali mobili che abbracciano i comodini.

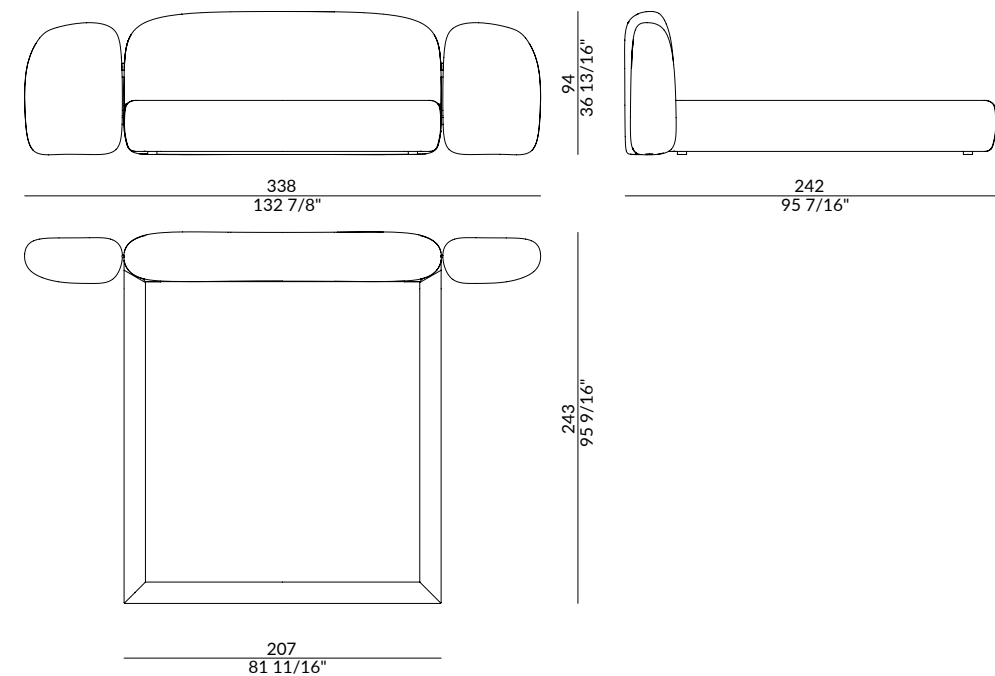

IMANE\_designer Thierry Lemaire, Hubert de Malherbe e Paolo Castelli

**IMANE is the new collection of OUTDOOR upholstered seats and coffee tables. Made with natural materials and handcrafted down to the smallest detail, IMANE is part of the larger project, THE GREENKISS, which includes the collections with a green soul of the company.** The IMANE sofas and armchairs are characterized by a linear structure in solid Iroko wood stained with natural oil, with a refined and essential image. The particularly resistant nature of Iroko, even greater after the curing process, makes this essence particularly suitable for external conditions. The structure accommodates large cushions in shaped polyurethane, a differentiated seat and back cushions in polyester staple with plexiglass insert. All cushions - including the loose ones that make the seat even more enveloping and comfortable - are covered with water-repellent polyester fiber fabric in variations of textures and colors, all designed for outdoor living.

**IMANE è la nuova collezione di sedute imbottite e coffee table per esterno. Realizzata con materiali naturali e curata artigianalmente fino ai minimi dettagli, IMANE rientra nel più ampio progetto GREENKISS, di cui fanno parte le collezioni dall'anima green dell'azienda.** I divani e le poltrone IMANE sono caratterizzate da una struttura lineare in legno massello di Iroko spazzolato tinto ad olio naturale, dall'immagine ricercata ed essenziale. La natura particolarmente resistente dell'Iroko, ancora maggiore dopo il processo di stagionatura, rende questa essenza particolarmente adatta alle condizioni esterne. La struttura accoglie grandi cuscini seduta in poliuretano sagomato a densità differenziata e cuscini schienale in fiocco di poliestere con inserto in plexiglass. Tutti i cuscini - compresi i cuscini volanti che rendono la seduta ancora più avvolgente e confortevole - sono rivestiti con tessuto in fibra di poliestere idrorepellente in tante varianti di texture e colori, tutte pensate per la vita outdoor.



IMANE SOFA 2 SEATS

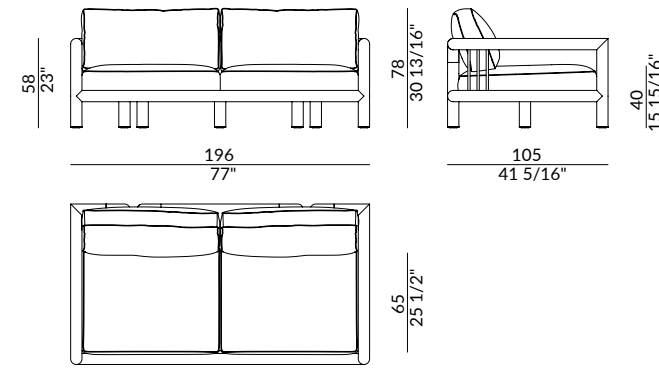

IMANE DAYBED

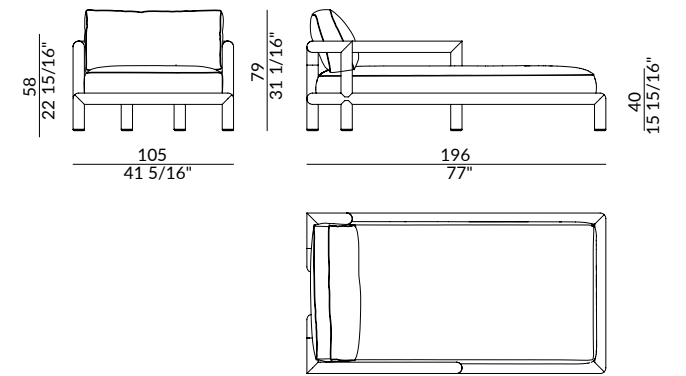

IMANE SOFA 3 SEATS

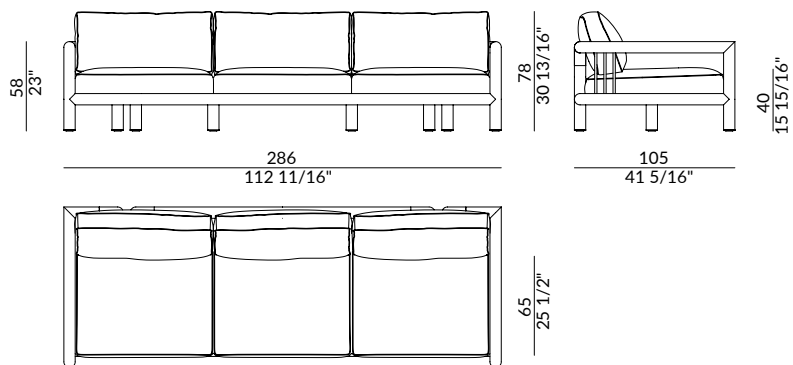

DECORATIVE PILLOWS

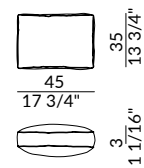

IMANE ARMCHAIR

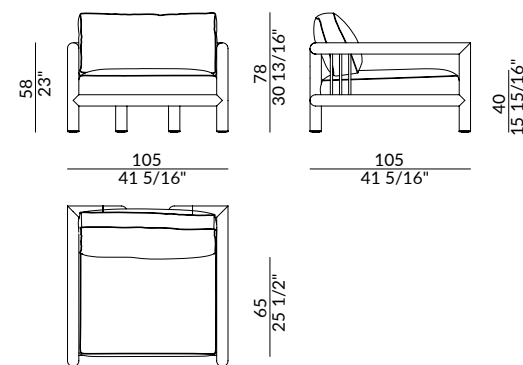

IMANE CHAIR

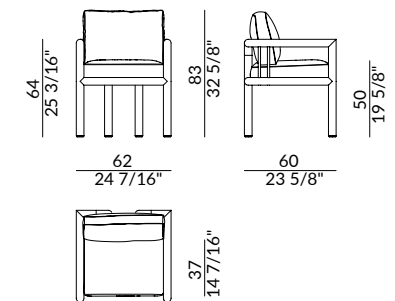

IMANE\_designer Thierry Lemaire, Hubert de Malherbe e Paolo Castelli

The IMANE coffee table has a linear structure in brushed solid Iroko wood stained with natural oil, with soft and expressive lines that look at the essentiality of Japanese furnishings. The top, made of natural white travertine with water and oil repellent treatment, rests on the structure giving the whole an unexpected light and natural effect.

Il coffee table IMANE ha una struttura lineare in legno massello di Iroko spazzolato tinto ad olio naturale, dalle linee morbide ed espressive che guardano all'essenzialità degli arredi giapponesi. Il piano, realizzato in Travertino bianco naturale con trattamento idro oleo repellente, si appoggia alla struttura regalando all'insieme un inaspettato effetto leggero e naturale.



IMANE DINING TABLE



IMANE COFFEE TABLE

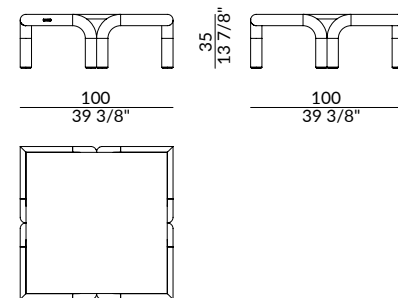
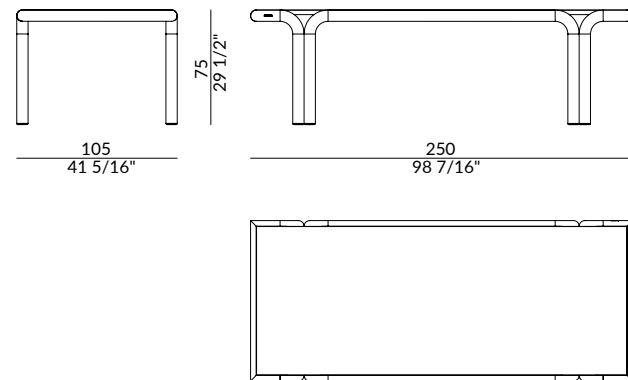

LAMPADA TERMINAL\_outdoor lamp design Paolo Castelli

The dedicated green line of products with a sustainable spirit is enriched with a new outdoor lamp in a suspended and applique version. Terminal lamp has a delicate and light shape reminding the one of the traditional insulators. The diffuser is made up of overlapping elements in borosilicate glass or hand-glazed Sicilian ceramic. In the center, a tubular body in perforated steel with a champagne-colored finish protects the IP67 LED source, is resistant to water and external agents.

La linea green dedicata di prodotti dallo spirito sostenibile si arricchisce di una nuova lampada da esterno in versione sospesa e applique. Terminal ha una forma delicata e leggera che ricorda quella dei tradizionali isolatori. Il diffusore è composto da elementi sovrapposti in vetro borosilicato o in ceramica siciliana smaltata a mano. Al centro un corpo tubolare in acciaio traforato con finitura color champagne protegge la sorgente a LED IP67, resistente all'acqua e agli agenti esterni.



TERMINAL SUSPENSION OUTDOOR



TERMINAL WALL OUTDOOR

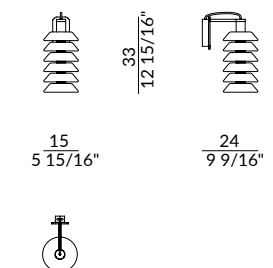
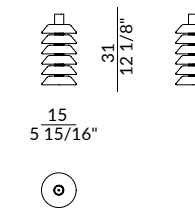

# PAOLO CASTELLI

The PAOLO CASTELLI collections are entirely made in Italy with the best craftsmanship: they embody a mix of design, innovation and tradition while focusing on eco-sustainability of the production chain.

Le collezioni PAOLO CASTELLI sono interamente realizzate in Italia dalle migliori artigianalità: un mix di design, innovazione, tradizione con un focus fondamentale sull'ecosostenibilità della filiera produttiva.





PAOLO CASTELLI

BOLOGNA  
Contract Office & Showroom

MILAN  
Contract Office & Showroom

PARIS  
Contract Office & Showroom

CARRARA  
Marine Division

HEADQUARTER VIA I° MAGGIO, 93 | 40064 OZZANO DELL'EMILIA | BOLOGNA - ITALY | TEL. +39 051 4695511 | [info@paolocastellispa.com](mailto:info@paolocastellispa.com)

[www.paolocastelli.com](http://www.paolocastelli.com)